

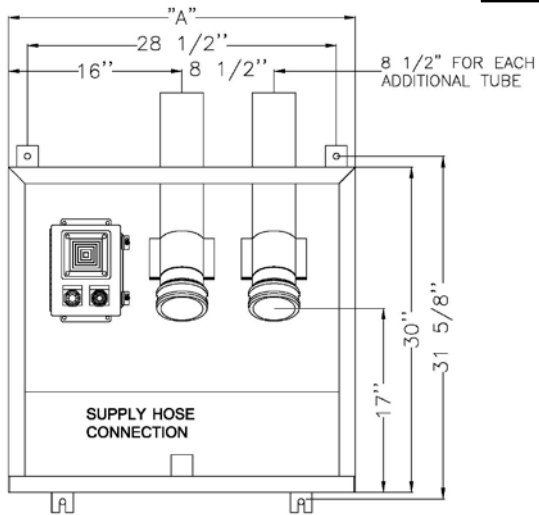

THE FRED D. PFENING COMPANY
DEDICATED TO THE BAKING
INDUSTRY SINCE 1919

BULK UNLOADING STATION

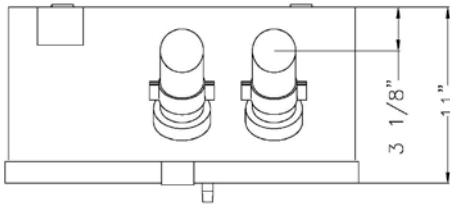

OPTION SILO
DRYER HOOKUP



Specifications

Finish: S.S. or C.S.

Tube Connection: Cam & Groove

Proximity Sensor: 110 VAC

Panel & Horn: 110 VAC

Optional Receptacle: 208/240/460 VAC

Mounting: Floor or Wall

# Tubes	"A"
1-2 Tube(s)...	30"
3 Tubes.....	42"
4 Tubes.....	48"

The Bulk Unloading Station is a lockable cabinet that contains the bin-fill connections for one or more storage bins. It may be used to unload bulk product from truck or rail car.

The Unloading Station Includes:

- Weather proof, corrosion resistant S.S. cabinet.
- Bin-fill tubes with cam & groove connections and dust caps.
- Proximity sensors to detect supply hose connection.
- Warning horn to indicate bin full.
- Unloading Panel includes: "Bin Ready to Fill" indicator light & 'Horn Off' push button.
- Product sight tubes installed above station.
- Optional power receptacle available inside cabinet.

THE FRED D. PFENING COMPANY
MANUFACTURERS OF
MATERIAL HANDLING, PROOFING,
AND LIQUID METERING SYSTEMS
Visit us at www.pfening.com

1075 WEST FIFTH AVENUE
COLUMBUS, OHIO 43212
PH. (614) 294-5361
FAX (614) 294-1633
email: sales@pfening.com

SPECIFY TO ORDER:

- CONTACT A PFENING SALES ENGINEER FOR ASSISTANCE IN SIZING YOUR BULK UNLOADING STATION.