

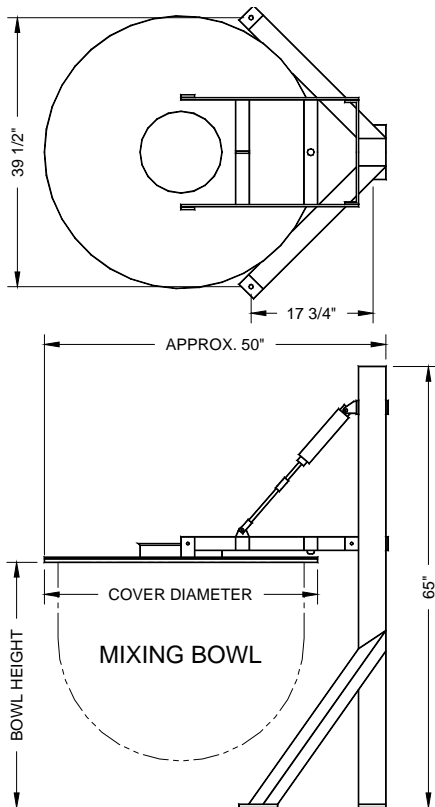

THE FRED D. PFENING COMPANY
DEDICATED TO THE BAKING
INDUSTRY SINCE 1919

BOWL COVER



Specifications

Operating Pressure: 60 psig min.

The Bowl Cover is designed to seal the rim of a mixing bowl to allow product from a hopper above it to be transferred into the bowl while sealing in the associated dust.

The Bowl Cover Includes:

- Sanitary welded rugged steel frame.
- Pneumatic cylinder operates on compressed in-plant air.
- Manual control valve with adjustable flow controls.
- Filter-Regulator with gage to condition air to control valve.
- Adjustable vertically position to fit standard mixing bowls.

THE FRED D. PFENING COMPANY
MANUFACTURERS OF
MATERIAL HANDLING, PROOFING,
AND LIQUID METERING SYSTEMS
Visit us at www.pfening.com

1075 WEST FIFTH AVENUE
COLUMBUS, OHIO 43212
PH. (614) 294-5361
FAX (614) 294-1633
email: sales@pfening.com

SPECIFY TO ORDER:

- CONTACT A PFENING SALES ENGINEER FOR ASSISTANCE IN SIZING YOUR BOWL COVER.