

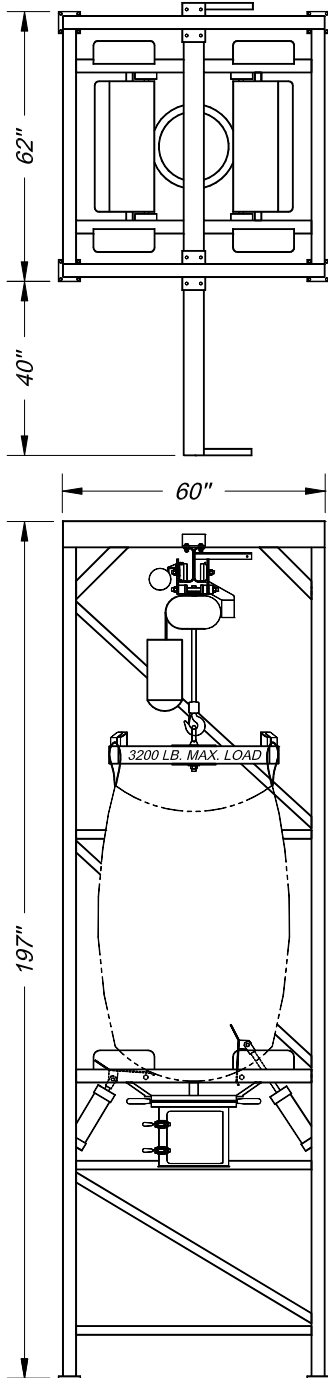

THE FRED D. PFENING COMPANY
DEDICATED TO THE BAKING
INDUSTRY SINCE 1919

BULK BAG UNLOADER



The Pfening Bulk Bag Unloader automatically discharges bulk bags. The material may be fed into an air conveying system or a mechanical feeder. A hoist and trolley is provided for lifting the bags into position.

The Bulk Bag Unloader Includes:

- Sanitary design built to BISSC standards.
- Heavy-duty frame for strength and rigidity.
- Pendant operated hoist with trolley for lifting bags into position.
- Air-operated bag flexing paddles to facilitate flow.
- Large diameter 16" discharge tube with dust tight access door for opening and closing bags.
- Full size 15" iris valve for closing off bag spouts with manual operator.
- Customized discharge hopper with connection to screw feeder, vacuum or pressure air conveyor, or other system.
- Optional load cells available.

Specification

- Support Frame:** 304 Stainless Steel Standard, Carbon Steel Available
- Hoist & Trolley:** 2-Ton Capacity
- Bag Flexers:** Air Operated
- Closure Valve:** 15" Manual Iris Type
- Weight:** 2200 lbs.
- Final Discharge:** Screw Feeder, Pressure or Vacuum Conveying
- Voltage:** 230-460/3/60



THE FRED D. PFENING COMPANY
MANUFACTURERS OF
MATERIAL HANDLING, PROOFING,
AND LIQUID METERING SYSTEMS
Visit us at www.pfening.com

1075 WEST FIFTH AVENUE
COLUMBUS, OHIO 43212
PH. (614) 294-5361
FAX (614) 294-1633
email: sales@pfening.com

SPECIFY TO ORDER:

- CONTACT A PFENING SALES ENGINEER FOR ASSISTANCE.