

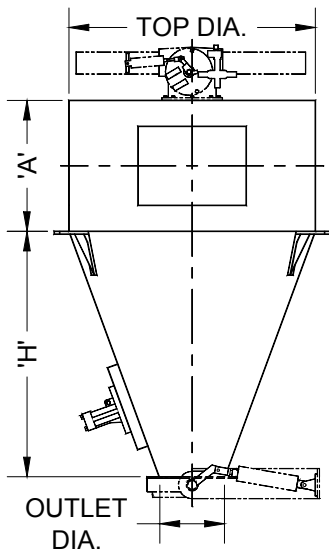

THE FRED D. PFENING COMPANY
DEDICATED TO THE BAKING
INDUSTRY SINCE 1919

SCALE HOPPER

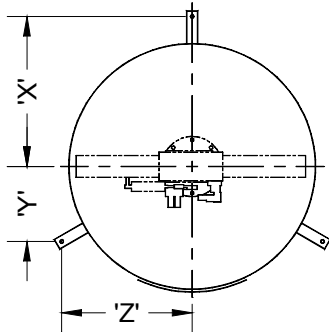

The Scale Hopper is designed to weigh material from a conveying system and discharge it into a mixer.

The Scale Hopper includes:

- Hopper capacities from 100 to 10,000 lbs.
- Stainless steel, mild steel, or aluminum construction.
- Meets BISSC standards; has continuous, sanitary welds throughout.
- Full size access door with handknobs.
- Top mounting flange for one to five Pfening Separator Valves.
- Bottom discharge flange for Pfening Butterfly Valve or Rotary Airlock.
- Three hanger brackets for load cells.
- Mounts for vibrator, vacuum relief valve, and evassors/fluidizers as specified.
- Special features, such as support frames, offset discharge, bin activator discharge and custom hangers are also available.
- *Accessories*, as italicized above are available, as well as *scale controllers*, *modular air filter-regulators*, *discharge sleeves*, and *special adapters*.



SIZE, TOP DIA., (IN)	36				45				60				72			
OUTLET DIA., (IN)	10		12		10		12		10		12		10		12	
CONE ANG., (DEG)	63	70	63	70	63	70	63	70	63	70	63	70	63	70	63	70
'H', (IN)	27.0	35.0	25.0	33.0	34.0	48.0	32.5	45.0	49.0	69.0	48.0	66.0	61.0	85.0	59.0	83.0
'X', (IN)	23.13				27.63				35.13				41.13			
'Y', (IN)	11.56				13.81				17.56				20.56			
'Z', (IN)	20.00				23.94				30.38				35.63			
CONE VOL., (CF)	7.2	9.5	7.2	9.4	13.2	18.6	13.4	18.6	31.8	44.8	26.9	44.5	55.5	77.3	55.4	77.9
STR. VOL., (CF/FT)	7.1				11				19.6				28.3			

THE FRED D. PFENING COMPANY
MANUFACTURERS OF
MATERIAL HANDLING, PROOFING,
AND LIQUID METERING SYSTEMS
Visit us at www.pfening.com

1075 WEST FIFTH AVENUE
COLUMBUS, OHIO 43212
PH. (614) 294-5361
FAX (614) 294-1633
email: sales@pfening.com

SPECIFY TO ORDER:

- CONTACT A PFENING SALES ENGINEER FOR ASSISTANCE IN SPECIFYING YOUR SCALE HOPPER.