

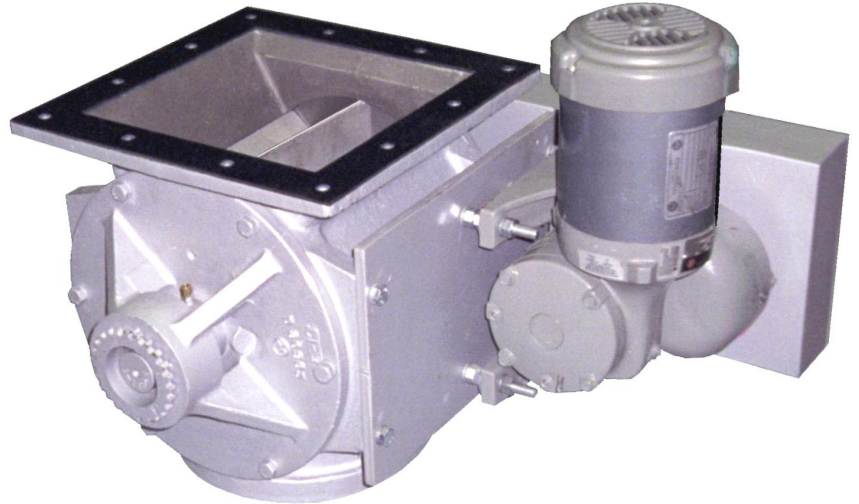

THE FRED D. PFENING COMPANY
DEDICATED TO THE BAKING
INDUSTRY SINCE 1919

MODEL 60 AIRLOCK

DIMENSIONS IN
INCHES [MILLIMETERS]

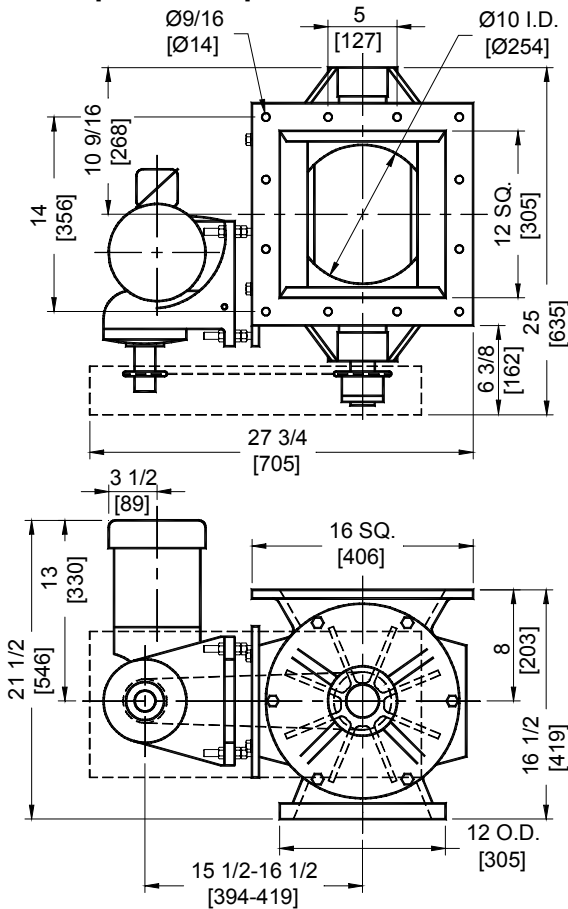

The Model 60 is a heavy-duty drop-through rotary airlock for steady feeding of bulk material from a bin or hopper.

The Model 60 includes:

- Heavy-duty cast iron body for durability.
- Rugged steel rotor, precision machined for smooth operation.
- Outboard bearings with inboard shaft seals for long bearing life and easy seal replacement.
- Gearmotor drive with OSHA chain guard.
- Vertical motor mount to minimize surface dust accumulation.
- Round discharge for easy connection of flexible sleeve.

Standard Specifications

Displacement: 0.64 ft³/rev.
Operating RPM: 0 to 40
Construction:
Body & Endplates: Cast Iron
Rotor: Steel
Electrical:
Voltage: 208-230-460V/3/60
 other voltages available
Motor: 1/2 HP TEFC
Weight: 245 lbs. (150 lbs. no drive)
 111 kg. (68 kg. no drive)

STANDARD FEATURES	FLOUR AIRLOCK	SUGAR AIRLOCK
Capacity	Up to 400 lbs./min. 182 kg./min.	Up to 500 lbs./min. 227 kg./min.
Rotor Vane	Standard	Beveled rotor tips
Rotor Clearance	.008" - .012"	.008" - .012"
Rotor Shaft Seals	PTFE impregnated packing w/ external gland	Pfening GR-4 air purge type airseal

THE FRED D. PFENING COMPANY
MANUFACTURERS OF
MATERIAL HANDLING, PROOFING,
AND LIQUID METERING SYSTEMS
Visit us at www.pfening.com

1075 WEST FIFTH AVENUE
COLUMBUS, OHIO 43212
PH. (614) 294-5361
FAX (614) 294-1633
email: sales@pfening.com

SPECIFY TO ORDER:

- PFENING MODEL 60 AIRLOCK
- EITHER FLOUR OR SUGAR
- EITHER WITH OR WITHOUT DRIVE
- RPM OR LBS/MIN. IF W/ DRIVE