



The Fred D. Pfening Company
Dedicated to the Baking
Industry Since 1919

MODEL 110A PROOF BOX

Pfening Proof Boxes Feature...

- Rugged corrosion resistant aluminum structural frame
- Sealed panels finished in natural aluminum, white enameled aluminum and stainless steel
- Heavy duty solid-core doors with rugged latches and hinges
- Pfening Model B Digital Controller accurate to within ½% for both temperature and relative humidity
- Caster racks or monorail design
- Either Dry (steam injected) or Wet (air wash) conditioning units
- Any size or configuration to meet your production requirements
- Special designs to meet your individual needs
- BISCC Approved
- The Pfening Equi-Temp air conditioning system

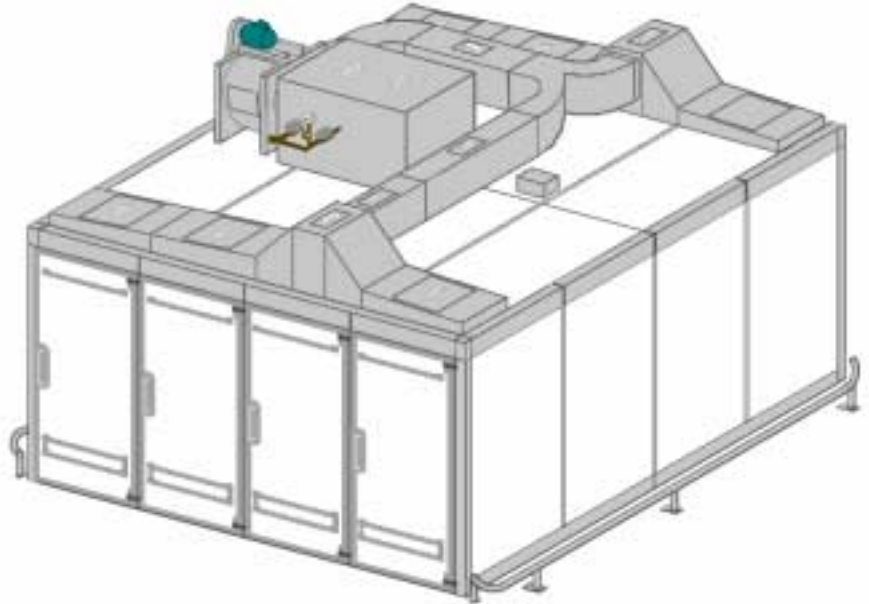

Pfening Equi-Temp™ Circulation *The Gentlest Whirlwind Ever Created*

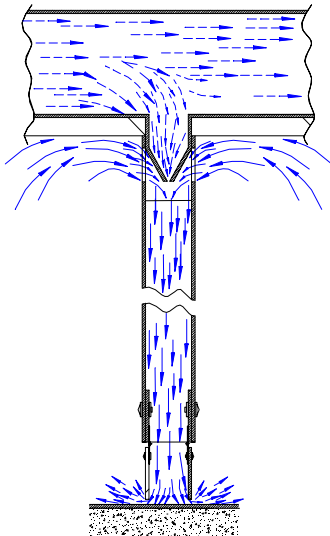

***Typical
Downspout***

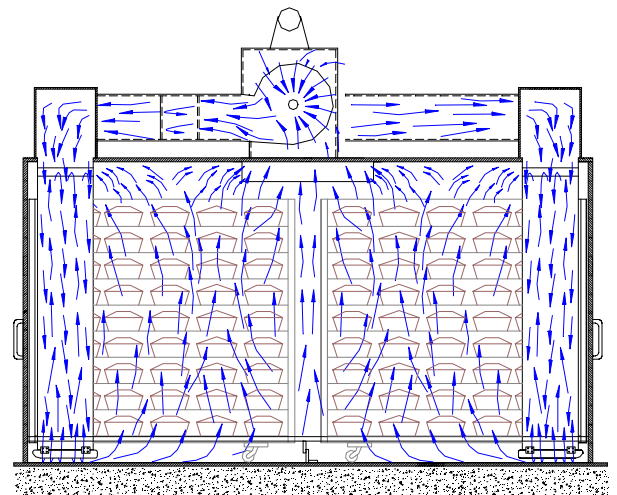
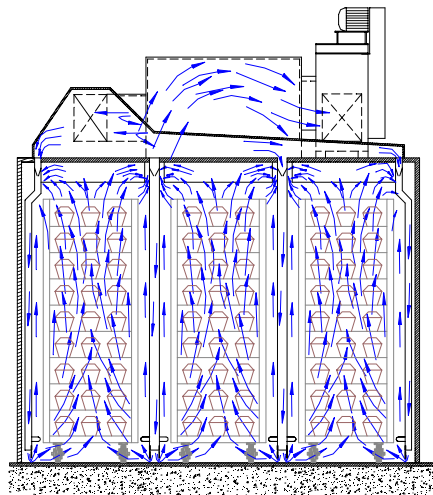

- Uniform temperature and humidity throughout the proof box
- Over 100 air changes per hour
- 43% newly conditioned air circulated through the radiator
- 57% recycled air drawn in at the ceiling
- Air discharged at the floor – drawn off at the ceiling

THE FRED D. PFENING COMPANY
MANUFACTURERS OF
MATERIAL HANDLING, PROOFING,
AND LIQUID METERING SYSTEMS
Visit us at www.pfening.com

1075 WEST FIFTH AVENUE
COLUMBUS, OHIO 43212
PH. (614) 294-5361
FAX (614) 294-1633
email: sales@pfening.com

SPECIFY TO ORDER:

- NUMBER OF LANES WIDE & RACKS DEEP
- RACK DIMENSIONS
- ELECTRICAL POWER SUPPLY VOLTAGE