

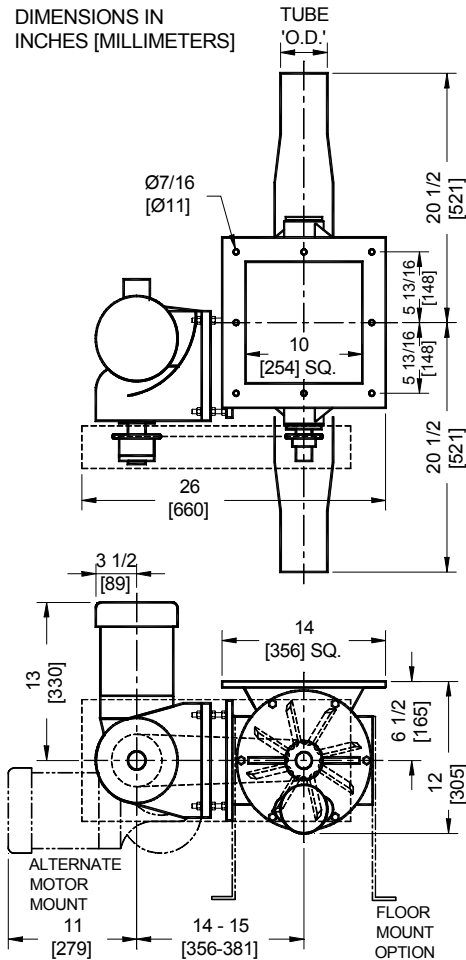

THE FRED D. PFENING COMPANY
DEDICATED TO THE BAKING
INDUSTRY SINCE 1919

MODEL 10 FEEDER

DIMENSIONS IN
INCHES [MILLIMETERS]



The Model 10 is a blow-through rotary airlock feeder typically mounted under a bin for steady feeding of bulk material into a pneumatic conveying line.

The Model 10 includes:

- Heavy-duty cast iron body for rigidity.
- Rugged steel rotor with oversize shaft for minimal deflection.
- Precision machining for smooth action and effective seal.
- Outboard bearings with inboard shaft seals for long bearing life and easy seal replacement.
- Heavy-duty gearmotor drive with OSHA chain guard.
- Vertical motor mount to minimize surface dust accumulation.

Standard Specifications

Displacement: 0.36 ft³/rev.
Operating RPM: 0 to 40
Tube O.D.: 3" to 5"
Construction:
Body & Endplates: Cast Iron
Rotor: Steel
Electrical:
Voltage: 208-230-460V/3/60
 other voltages available
Motor: 1/2 HP TEFC
Weight: 250 lbs. (180 lbs. no drive)
 113 kg. (82 kg. no drive)

STANDARD FEATURES	FLOUR FEEDER	SUGAR FEEDER
Capacity	Up to 300 lbs./min. 136 kg./min.	Up to 350 lbs./min. 159 kg./min.
Rotor Vane	Standard	Beveled rotor tips Skewed rotor vanes
Rotor Clearance	.002" - .005"	.007" - .009"
Rotor Shaft Seals	PTFE impregnated packing w/ external gland	Pfening GR-4 air purge type airseal

THE FRED D. PFENING COMPANY
MANUFACTURERS OF
MATERIAL HANDLING, PROOFING,
AND LIQUID METERING SYSTEMS
Visit us at www.pfening.com

1075 WEST FIFTH AVENUE
COLUMBUS, OHIO 43212
PH. (614) 294-5361
FAX (614) 294-1633
email: sales@pfening.com

SPECIFY TO ORDER:

- PFENING MODEL 10 FEEDER
- EITHER FLOUR OR SUGAR
- INLET/OUTLET TUBE O.D.
- EITHER WITH OR WITHOUT DRIVE
- RPM OR LBS/MIN. IF W/ DRIVE