

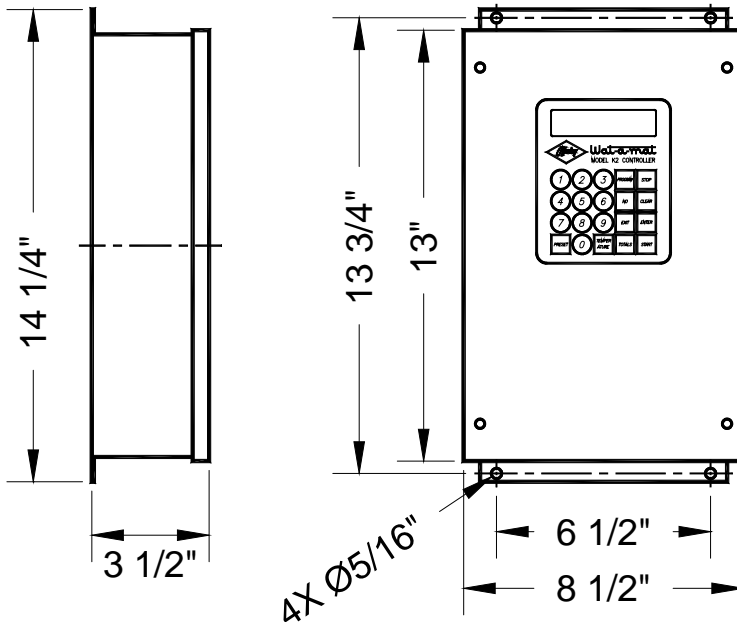

THE FRED D. PFENING COMPANY
DEDICATED TO THE BAKING
INDUSTRY SINCE 1919

MODEL K2 LIQUID METER CONTROL



Electrical Specifications:

Inputs:

Power:	120 VAC, 2A fused
Counter:	Dry contact or current-sinking TTL type (compatible with Hall-effect and magneto-resistive sensors)
Temperature:	RTD sensor
Remote Start/Stop:	Dry contacts
Blender Valve Position:	Potentiometer

Outputs:

Flow valve:	120 VAC Relay
Blend motor:	CW & CCW 120 VAC Triacs
Reject valve:	120 VAC Relay

The Model K2 is a liquid meter control designed specifically for batching liquids in production facilities. It includes temperature display and control options.

The Model K2 includes:

- Easy to read four-line LCD display.
- 20 key waterproof touchpad for ease of operation.
- Simple operation with operator prompts.
- Up to 6 setpoints for temperature and batch size.
- Temperature display and control options – fully compatible with Pfening Automatic water blenders.
- Splash proof stainless steel enclosure.
- Count and batch totalizers.

THE FRED D. PFENING COMPANY
MANUFACTURERS OF
MATERIAL HANDLING, PROOFING,
AND LIQUID METERING SYSTEMS
Visit us at www.pfening.com

1075 WEST FIFTH AVENUE
COLUMBUS, OHIO 43212
PH. (614) 294-5361
FAX (614) 294-1633
email: sales@pfening.com

SPECIFY TO ORDER:

- CONTACT A PFENING SALES AGENT FOR ASSISTANCE IN ORDERING YOUR CONTROL.