

REMOVE ACTUATOR &
ALL SEATING MATERIALS
BEFORE WELDING

NOTES

- TOLERANCE ON DIMENSIONS WITH 3 DECIMAL POINTS (0.000) = ± 0.010 ".
- CHAMFER ALL EDGES.
- ALL MACHINED SURFACES FINISHED 63 RMS (OR BETTER).
- REMOVE ALL HEAT TINT.

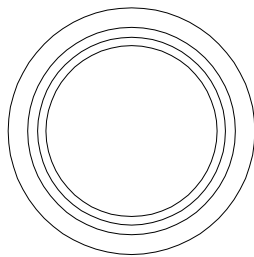

② DETAIL ITEM
(FULL SCALE)

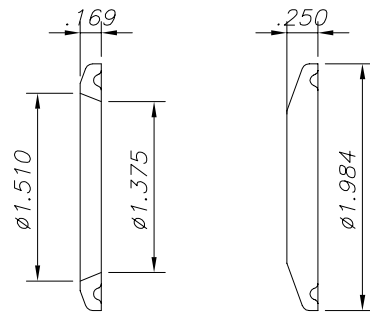

② BEFORE MACHINING

ITEM	PART NO.	QTY	DESCRIPTION
1	PURCH	2	1 1/2" TRI-CLAMP SOLID ENDCAP; RJ SALES #RJ16AMP-1 1/2"
1	PURCH	1	ASCO 1 1/4" ANGLE SEAT VALVE - BUTT WELD CONNECTIONS; S290A215

LIST OF MATERIALS

REVISIONS	DESCRIPTION

MARK V WAT-A-MAT
AIR OPERATED S/S SHUT-OFF VALVE

DRAWN T. L. WHITE
DATE 11-19-02

CHECKED
SCALE HALF

THE FRED D. PFENING CO.
COLUMBUS, OHIO 43212

DRAWING NUMBER
B60005

REVISION